

## Wireless communications for underground mining safety

Naga Amar Chaitanya. P<sup>1</sup>, G.Divya<sup>2</sup>, C.Ashok Kumar<sup>3</sup>

<sup>1</sup>, Dept Of ECE, CMR Engineering College, Hyderabad, Telangana.

<sup>2</sup>, Assistant professor, CMR Engineering College, Hyderabad, Telangana.

<sup>3</sup>, Associate Professor, CMR Engineering College, Hyderabad, Telangana.

### Abstract:

This paper presents a low power, cost-effective, And Zigbee protocol based wireless sensor network that provides an intelligent surveillance and safety system for underground coal mines. The system consists of wireless connection of several nodes. Sensor node mainly consists of Zigbee protocol based low power CC2530 transceiver integrated with a high performance, low power microcontroller on single chip. This integrated chip connected through RF connector on smartRF05 Battery Board. This small size, low power device is easily interfaced with desired miniature size sensors. Wireless sensor nodes join to other sensor node in specific multi-hop mesh network topology, that creates a Zig8ee based wireless sensor network. This network can be easily placed in underground mines and it provides an effectively surveillance and safety system for underground coal miners. Especially, it provides the real-time data communication between miners and surface control room through highly secure, reliable wireless sensor nodes. The proposed system improves the existing miner's safety and early warning surveillance in underground coal mines

**Key words:** Temp sensor, humidity, smoke, gas sensor, Zigbee, GSM

### I. Introduction

The mining industry plays a vital role in the global economy. The current estimated market capitalization of global mining companies is about \$962 billion . A large portion of these operations are underground and involve specialized equipment and processes. Communication systems play an increasingly important role in ensuring personnel safety and optimizing the mining process. The estimated size of underground mining equipment market alone is currently about \$45 billion [3], a small but important portion of which is allocated communications systems. Although interest in deploying wireless communication systems in underground mines dates back to the 1920's, the first wide deployment didn't take place until the early 1970's when the mining industry began to deploy very-high-frequency (VHF) radios and leaky feeder distribution systems [6]-[10]. The modern era of underground communications began in the early 2000's as the mining industry sought to take advantage of considerable advances in wireless communications. Although the mining industry is inherently conservative and reluctant to invest in costly new technologies, high profile accidents often prompted regulators to require that the mining (and mining communications) industry devote increasing attention to safety and safety communications . Recent interest in deploying next generation wireless communications technology in underground mines has stemmed from recent advances in short-range wireless communications technology In an

underground mine, there are three possible mechanisms for communication signaling: through zigbee

### The Hardware System

**ARM7TDMI:** ARM is the abbreviation of Advanced RISC Machines, it is the name of a class of processors, and is the name of a kind technology too. The RISC instruction set, and related decode mechanism are much simpler than those of Complex Instruction Set Computer (CISC) designs.

**Liquid-crystal display (LCD)** is a flat panel display, electronic visual display that uses the light modulation properties of liquid crystals. Liquid crystals do not emit light directly. LCDs are available to display arbitrary images or fixed images which can be displayed or hidden, such as preset words, digits, and 7-segment displays as in a digital clock. They use the same basic technology, except that arbitrary images are made up of a large number of small pixels, while other displays have larger elements.

### I. Design of Proposed Hardware System

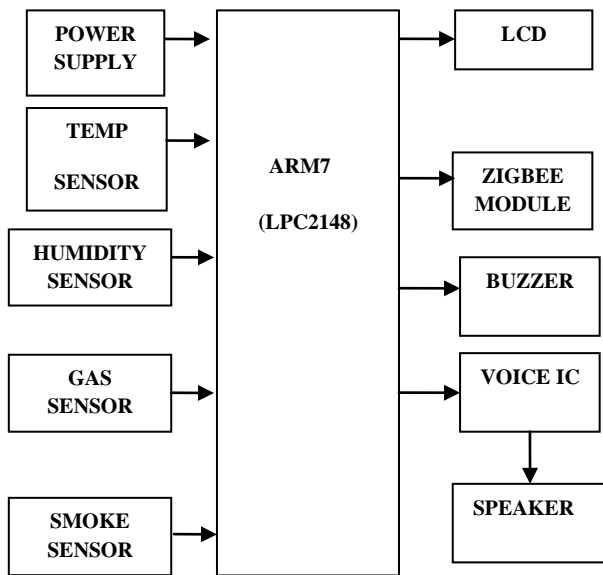

Fig.1.Blockdiagram

are most frequently used to provide mobile internet connectivity, many of them can also be used for sending and receiving SMS .

**Zigbee**

Zigbee modules feature a UART interface, which allows any microcontroller or microprocessor to immediately use the services of the Zigbee protocol. All a Zigbee hardware designer has to do in this case is ensure that the host's serial port logic levels are compatible with the XBee's 2.8- to 3.4-V logic levels. The logic level conversion can be performed using either a standard RS-232 IC or logic level translators such as the 74LVTH125 when the host is directly connected to the XBee UART. The below table gives the pin description of transceiver. The X-Bee RF Modules interface to a host device through a logic-level asynchronous Serial port. Through its serial port, the module can communicate with any logic and voltage Compatible UART; or through a level translator to any serial device.

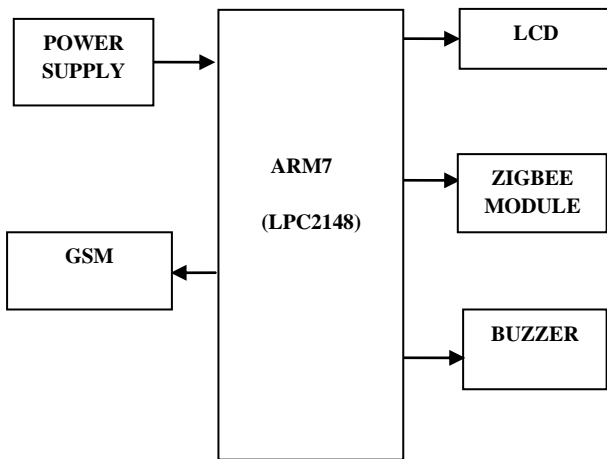

Fig.2.Block diagram

Data is presented to the X-Bee module through its DIN pin, and it must be in the asynchronous serial format, which consists of a start bit, 8 data bits, and a stop bit. Because the input data goes directly into the input of a UART within the X-Bee module, no bit inversions are necessary within the asynchronous serial data stream. All of the required timing and parity checking is automatically taken care of by the X-Bee's UART.



**Features:**

- Internal Sourcing of almost all of main Parts

**Board Hardware Resources Features**

**GSM**

Global System for Mobile Communication (GSM) is a set of ETSI standards specifying the infrastructure for a digital cellular service. The standard is used in approx. 85 countries in the world including such locations as Europe, Japan and Australia. GSM modem is a specialized type of modem which accepts a SIM card, and operates over a subscription to a mobile operator, just like a mobile phone. From the mobile operator perspective, a GSM modem looks just like a mobile phone. When a GSM modem is connected to a computer, this allows the computer to use the GSM modem to communicate over the mobile network. While these GSM modems

Almost all components - frame, key switches and membrane sheet - other than connectors and cord are manufactured in-house, giving Minebea an unmatched advantage in terms of quality, supply capabilities, cost-competitiveness and speed of delivery.

Especially, these products capitalize on Minebea's ultra-precision machining technology of components.

- **Efficient Production System**

Plant in China which supplies the global market employs the Minebea's vertically integrated manufacturing system, whereby all process, from machining components to final assembly are conducted in-house.

### **SENSORS:**

#### **Thermistor**

A **thermistor** is a type of resistor whose resistance varies significantly with temperature, more so than in standard resistors. The word is a portmanteau of thermal and resistor. Thermistors are widely used as inrush current limiters, temperature sensors, self-resetting over current protectors, and self-regulating heating elements. Thermistors differ from resistance temperature detectors (RTD) in that the material used in a thermistor is generally a ceramic or polymer, while RTDs use pure metals. The temperature response is also different; RTDs are useful over larger temperature ranges, while thermistors typically achieve a higher precision within a limited temperature range, typically  $-90\text{ }^{\circ}\text{C}$  to  $130\text{ }^{\circ}\text{C}$ .

**SMOKE SENSOR:** Smoke sensor is used to detect any leakage of smoke and any hazardous gases such that an alarm can be initiated to avoid any damages in the industries. These sensors are also used in many applications like corporate and in any office work areas these are linked to fire alarms. And buzzers through the micro-controller. There are two main types of smoke detectors: Ionization detectors and photoelectric detectors. A smoke alarm uses one or both methods, sometimes plus a heat detector, to warn of a fire. Ionization detectors have an ionization chamber and a source of ionizing radiation. The source of ionizing radiation is a minute quantity of americium-241 (perhaps 1/5000th of a gram), which is a source of alpha particles (helium nuclei). The ionization chamber consists of two plates separated by about a centimeter. The battery applies a voltage to the plates, charging one plate positive and the other plate negative. Alpha particles constantly released by the americium knock electrons off of the atoms in the air, ionizing the oxygen and nitrogen atoms in the chamber. The positively-charged oxygen particles attach to the ions and neutralize them, so they do not reach the plate. The drop in current between the plates triggers the alarm. In one type of photoelectric device, smoke can block a light beam. In this case, the reduction in light reaching a photocell sets off the alarm. In the most common type of photoelectric unit, however, light is scattered by smoke particles onto a photocell, initiating an alarm. In this type of detector

there is a T-shaped chamber with a light-emitting diode (LED) that shoots a beam of light across the horizontal bar of the T. A photocell, positioned at the bottom of the vertical base of the T, generates a current when it is exposed to light. Under smoke-free conditions, the light beam crosses the top of the T in an uninterrupted straight line, not striking the photocell positioned at a right angle below the beam. When smoke is present, the light is scattered by smoke particles, and some of the light is directed down the vertical part of the T to strike the photocell. When sufficient light hits the cell, the current triggers the alarm.



#### **HUMIDITY:**

Humidity is the amount of water vapor in the air. In daily language the term "humidity" is normally taken to mean relative humidity. Relative humidity is defined as the ratio of the partial pressure of water vapor in a parcel of air to the saturated vapor pressure of water vapor at a prescribed temperature. Humidity may also be expressed as absolute humidity and specific humidity. Relative humidity is an important metric used in forecasting weather. Humidity indicates the likelihood of precipitation, dew, or fog. High humidity makes people feel hotter outside in the summer because it reduces the effectiveness of sweating to cool the body by preventing the evaporation of perspiration from the skin. Absolute humidity is the quantity of water in a particular volume of air. The most common units are grams per cubic meter, although any mass unit and any volume unit could be used. Relative humidity is defined as the ratio of the partial pressure of water vapor in a gaseous mixture of air and water vapor to the saturated vapor pressure of water at a given temperature. Relative humidity is expressed as a percentage. Specific humidity is the ratio of water vapor to air (including water vapor and dry air) in a particular volume. Measuring and regulating humidity.



#### **Gas Sensor**

Gas sensor an Alumina tube cover by SnO<sub>2</sub>, which is tin dioxide. And between them there is an Aurum electrode, the black one. And also you can see how the wires are connected. So, why do we need them? Basically, the alumina tube and the coils are the heating system, the yellow, brown parts and the coils in the picture

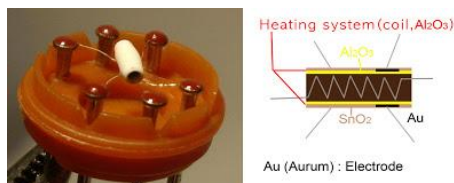

SnO<sub>2</sub> ceramics will become the semi-conductor, so there are more movable electrons, which means that it is ready to make more current flow when the alcohol molecules in the air meet the electrode that is between alumina and tin dioxide, ethanol burns into acetic acid then more current is produced. So the more alcohol molecules there are, the more current we will get. Because of this current change, we get the different values from the sensor.

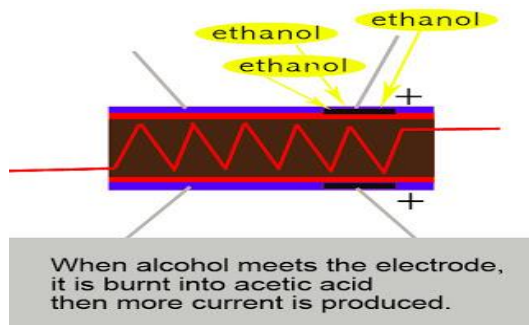

### Conclusion

The need for wireless communication in the underground mining industry has evolved person-to-person communication through mobile and to high speed it is Observed that Zigbee based wireless transmission is most suitable for underground coal mines for its low power, low cost intrinsic safe characteristics. Real time environmental data in underground mines are collected through sensor nodes and continuous data transmission to the surface control room is possible through wireless network. This will enhance the safety of the miners working underground with additional reliability and flexibility.

### REFERENCES

[1] "Mining." [Online]. Available: <http://en.wikipedia.org/wiki/Mining>  
 [2] "Mine 2010: Back to the boom," Price Waterhouse Coopers, 2010.

[3] "World mining equipment: Industry forecasts for 2013 and 2018," Freedonia Group, 2009.  
 [4] D. G. Large, L. Ball, and A. J. Farstad, "Radio transmission to and from underground coal mines-Theory and experiment," IEEE Trans. Commun., vol. 21, pp. 194–202, 1973.  
 [5] R. S. Nutter and M. D. Aldridge, "Status of mine monitoring and communications," IEEE Trans. Ind. Appl., vol. 24, pp. 820–826, 1988.  
 [6] P. Delogne, "The INIEX mine communications systems," in Proc. Radio: Roads Tunnels Mines, Apr. 1974, pp. 129–136.  
 [7] J. Murphy and H. E. Parkinson, "Underground mine communications," in Proc. IEEE, Jan. 1978, pp. 26–50.  
 [8] D. J. R. Martin and R. Webster, "The use of radio in British coal mines," in Proc. Radio: Road Tunnels Mines, Apr. 1974, pp. 110–128.  
 [9] D. J. R. Martin, "Leaky-feeder radio communication: A historical review," in Proc. IEEE VTC, May 1984, pp. 25–30.  
 [10] P. Delogne, "EM propagation in tunnels," IEEE Trans. Antennas Propag., vol. 39, pp. 401–406, 1991.  
 [11] "Underground coal mining disasters and fatalities-U.S. 1900-2006." [Online]. Available: <http://www.cdc.gov/mmwr/preview/mmwrhtml/mm5751a3.htm>  
 [12] L. K. Bandyopadhyay, S. K. Chaulya, P. K. Mishra, and A. Choure, "Wireless information and safety system for underground mines," in Proc. URSI, Aug 2008, pp. 9–16.  
 [13] K. Srinivasan, M. Ndoh, and K. Kaluri, "Advanced wireless networks for underground mine communications," in Proc. IEEE ICWCUCA, Jun. 2005, pp. 51–54.  
 [14] W. H. Schiffbauer and J. F. Brune, "Coal mine communications," American Longwall Mag., 2006.  
 [15] P. Laliberte, "Summary study of underground communication technologies-Final project report," CANMET, 2009.  
 [16] "OMSHR." [Online]. Available: <http://www.cdc.gov/niosh/mining/works/publicationlist.html>  
 [17] S. Yarkan, S. Guzelgoz, H. Arslan, and R. Murphy, "Underground mine communications: A survey," IEEE Commun. Surv. Tutorials, vol. 11, pp. 125–142, 2009.  
 [18] T. Sarkar, Z. Ji, K. Kim, A. Medouri, and M. Salazar-Palma, "A survey of various propagation models for mobile communication," IEEE Trans. Antennas Propag., vol. 45, pp. 51–82, 2003.  
 [19] D. G. Michelson and S. S. Ghassemzadeh, "Measurement and modeling of wireless

- channels,” in *New Directions in Wireless Communications Research*, V. Tarokh, Ed. Springer, 2009, ch. 1, pp. 1–27.
- [20] W. Pittman and R. Church, “Through-the-earth electromagnetic trapped miner location systems: A review,” Bureau of Mines, 1985.
- [21] D. Hill and J. Wait, “Theoretical noise and propagation models for through-the-earth communication,” U.S. Bureau Mines, 1982.
- [22] J. Durkin, “Apparent earth conductivity over coal mines as estimated from through-the-earth electromagnetic transmission tests,” U.S. Bureau of Mines, 1984.
- [23] T. D. Barkand, N. W. Damiano, and W. A. Shumaker, “Through-theearth, two-way, mine emergency, voice communication systems,” in *Proc. IAS*, Oct. 2006, pp. 955–958.
- [24] C. J. Bise, R. Ferriter, J. Joy, J. A. Lamonica, D. Lauriski, J. Main, J. N. Murphy, and W. York-Feirn, “Improving mine safety technology and training: Establishing U.S. global leadership,” *Mine Safety Technol. Training Commission*, pp. 2–4, 2006.
- [25] “Mine site technologies.” [Online]. Available: <http://www.minesite.com.au/applications>
- [26] M. Linard and P. Degauque, “Natural wave propagation in mine environments,” *IEEE Trans. Antennas Propag.*, vol. 48, pp. 1326–1339, 2000.
- [27] A. Chehri, P. Fortier, and P. M. Tardif, “UWB-based sensor networks for localization in mining environments,” *Elsevier Ad Hoc Netw.*, vol. 7, pp. 987–1000, 2009.
- [28] D. Frielos, “Xstrata mines RFID’ sbenefits,” *RFID J.*, 2007.
- [29] “Becker Varis.” [Online]. Available: <http://www.varismine.com>
- [30] D. A. Hill, *Radio Wave Propagation Ground Effects*, V. Tarokh, Ed. Wiley, 2005.
- [31] A. C. Tripp, R. McNearny, and C. Furse, “Prof. James R. Wait and mining production technology-An appreciation,” *IEEE Trans. Antennas Propag.*, vol. 48, pp. 1438–1441, 2000.
- [32] S. F. Mahmoud, “On the attenuation of monofilar and bifilar modes in mine tunnels,” *IEEE Trans. Microw. Theory Techn.*, vol. 22, pp. 845–847, 1974.
- [33] S. F. Mahmoud and J. R. Wait, “Theory of wave propagation along a thin wire inside a rectangular waveguide,” *Radio Sci.*, vol. 9, pp. 417–420, 1974.
- [34] D. T. Updyke, W. C. Muhler, and H. C. Turnage, “An evaluation of leaky feeder communication in underground mines,” U. S. Dept. Interior, Bureau of Mines, 1980.
- [35] A. G. Emslie, R. L. Lagace, and P. F. Strong, “Theory of the propagation of UHF radio waves in coal mine tunnels,” *IEEE Trans. Antennas Propag.*, vol. 23, pp. 192–205, 1975.
- [36] E. A. J. Marcatili and R. A. Schmeltzer, “Hollow metallic and dielectric wave-guides for long distance optical transmission and lasers,” *Bell Syst. Tech. J.*, vol. 43, pp. 1783–1809, 1964.
- [37] J. I. Glaser, “Attenuation and guidance of modes on hollow dielectric waveguides,” *IEEE Trans. Microw. Theory Techn.*, vol. 17, pp. 173–174, 1969.
- [38] G. Emslie, R. L. Lagace, and P. F. Strong, “Theory of the propagation of UHF radio waves in coal mine tunnels,” in *Proc. Mines Golden Colo.*, Aug. 1973.
- [39] C. Nerguizian, C. Despins, S. Affes, and M. Djadel, “Radio-channel characterization of an underground mine at 2.4 GHz,” *IEEE Trans. Wireless Commun.*, vol. 4, pp. 2441–2453, 2005.
- [40] S. R. Saunders and A. Aragon-Zavala, *Antennas and Propagation for Wireless Communication Systems*. Chichester, England: Wiley, 2007.